



CITCRYO4-16

Cryogenic HEMT Low Noise Amplifier

KEY FEATURES

- Very low noise, of the order of 5K over an extremely wide bandwidth, 4 to 16 GHz. Usable from 3 to 18 GHz.
- Operates with wide range of DC supply voltage.
- Provides usable gain and noise at DC power as low as 10 mW.
- Input return loss is <-10 dB from 4 to 16 GHz.

PERFORMANCE FEATURES

- RF frequency
 - 4 to 16 GHz
- Gain
 - 38 dB \pm 2 dB
- Average noise temperature
 - <5 Kelvin
- Average noise figure
 - <0.08 dB

APPLICATIONS

- ✓ Radio astronomy arrays
- ✓ Satellite and Space Communication
- ✓ Research & development



Description

- The CITCRYO4-16 is a GaAs HEMT cryogenic, low noise, broadband amplifier. It utilizes SMA jacks for RF-input and output and a 4-pin 2 mm pitch header for DC bias. The amplifier requires one drain voltage in the 0.6V to 1.5V range and one gate voltage in the -3V to +1V range. If desired, the gate supply can be eliminated (open pins on Vg1 and Vg2) at slightly less than optimum performance.
- The amplifier may be operated at room temperature to give a noise figure <1.7 dB and gain 30 dB. Note that a more negative gate supply voltage, typically -1.5V, is required at room temperature. However, the amplifier is not damaged if the gate voltage for cryogenic operation, typically 0V, is applied at room temperature (though the gain is very low). Input and output return loss change very little from 300K to 4K.

Electrical Specifications @ 12 K

Description	Typical	Minimum	Maximum
RF Frequency		4 GHz	16 GHz
Gain	38 dB	38 dB ± 2 dB	
Noise Temperature	< 5 K		
IRL (-20log S ₁₁)		< -10 dB (8-16 GHz)	
ORL (-20log S ₂₂)		< -10 dB (3-16 GHz)	
Drain Voltage	1.2 V	0.6 V	1.5 V

Electrical Specifications @ 300 K

Description	Typical	Minimum	Maximum
RF Frequency		4 GHz	16 GHz
Gain	38 dB	38 dB ± 2 dB	
Noise Temperature	120 K		
IRL (-20log S ₁₁)		< -10 dB (8-16 GHz)	
ORL (-20log S ₂₂)		< -10 dB (3-16 GHz)	
DC Voltage	1.5 V	0.6 V	1.5 V

Typical Test Results – Optimum DC Bias @ 19 K

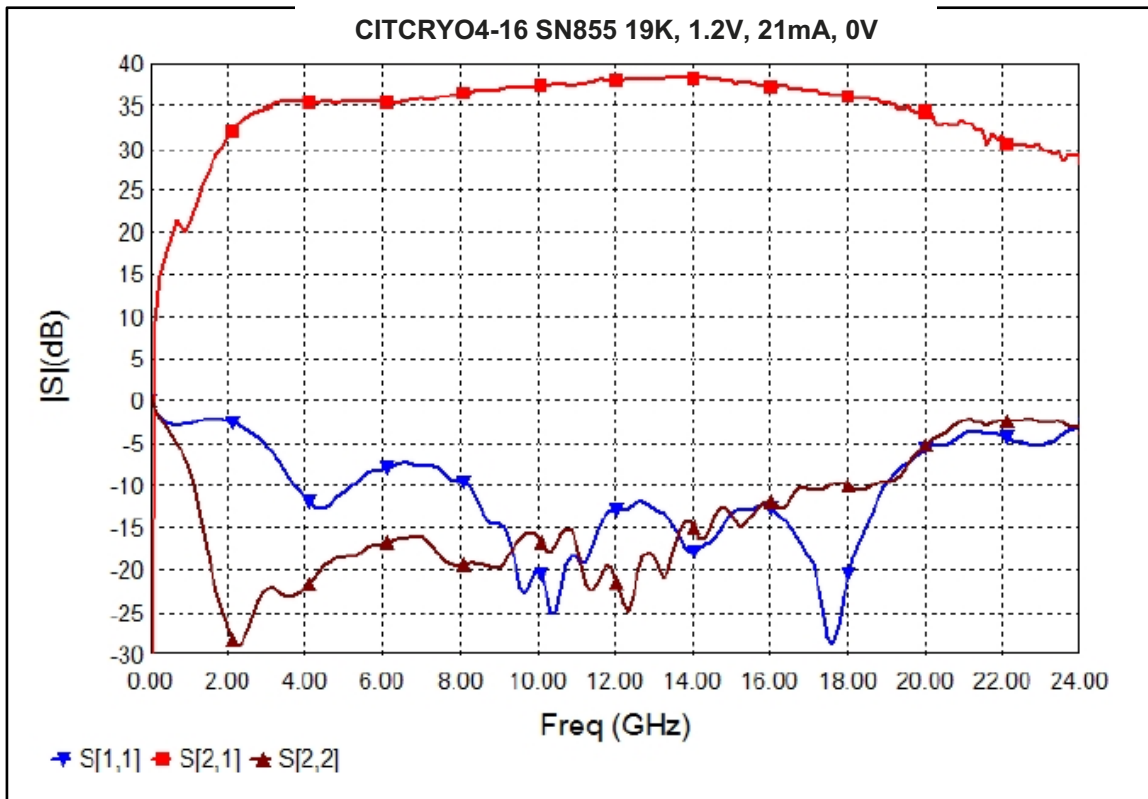
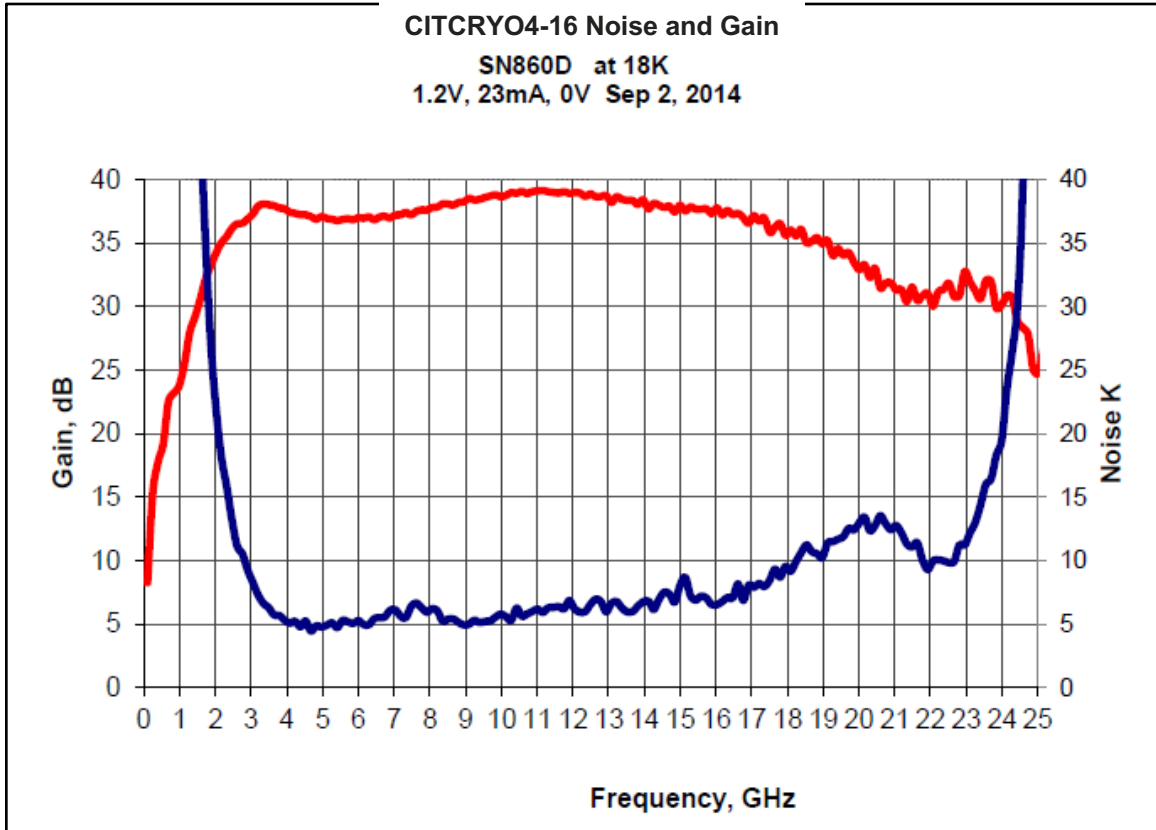

Typical Test Results – Optimum DC Bias @ 300 K

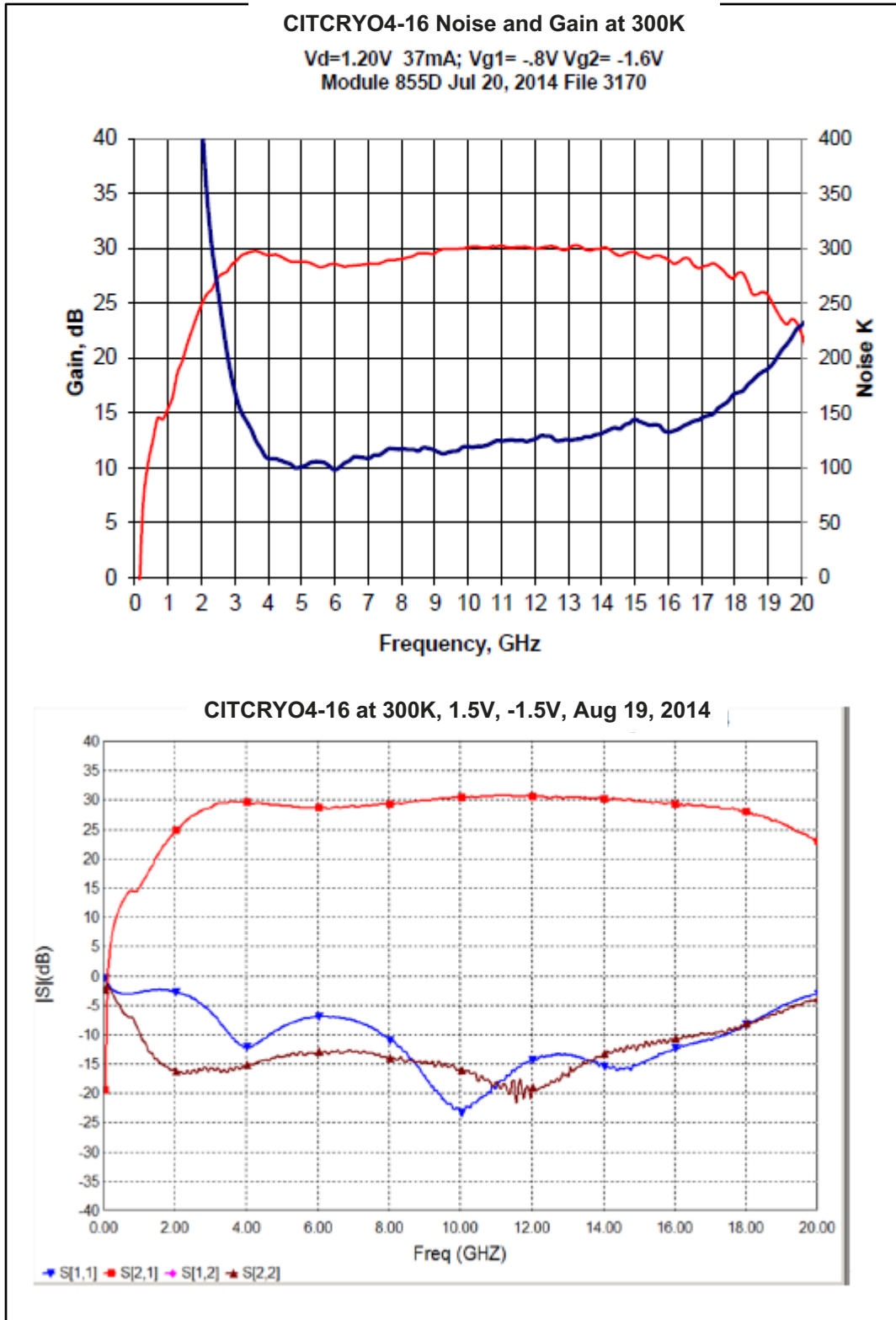

CAD Housing Drawing

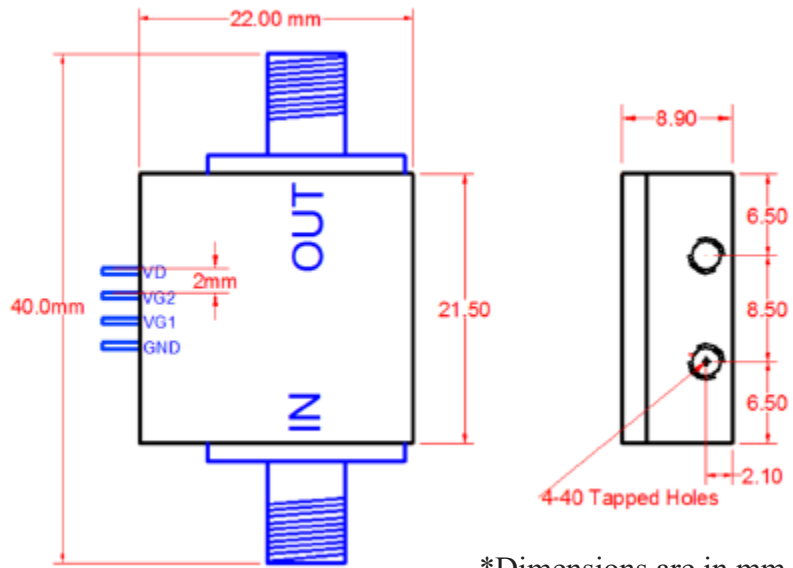
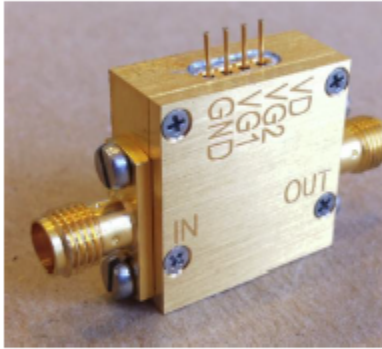

*Dimensions are in mm

Optional Input Bias Tee

As an option, the amplifier can be supplied with a DC bias tee for an external device connected to the amplifier input. The bias tee is formed by two (2) resistors connected to the input; as shown in Figure 1. One (1) resistor can be used as a source of current and the other senses the voltage across the external device. Voltages applied to the bias tee have a small effect on amplifier operation. At 12 K, 20 KΩ resistors increase noise by 0.5 K.

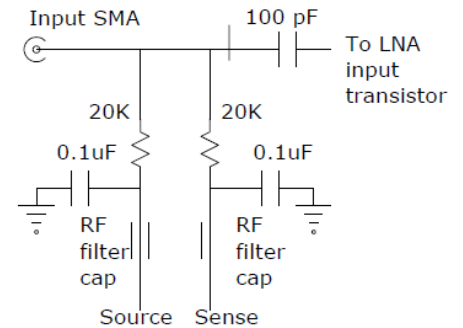
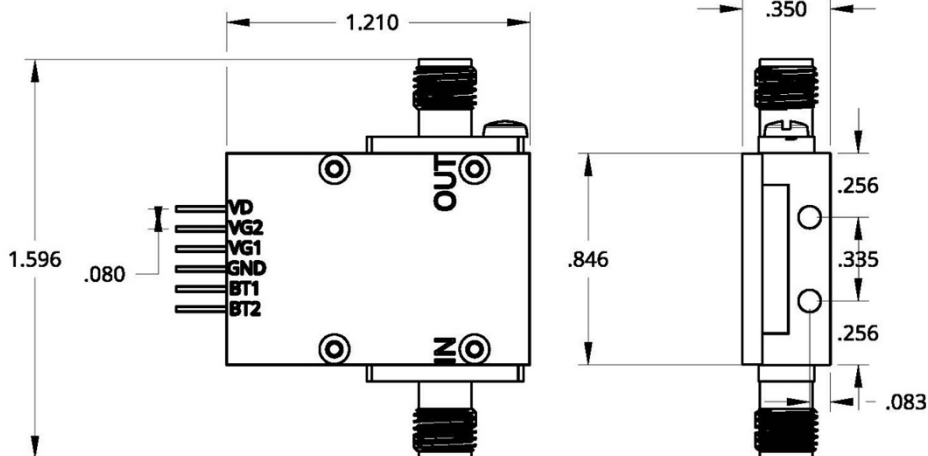

Figure 1. Bias Tee Schematic



Optional Input Protection Diodes

As an option, the amplifier can be supplied with ESD protection & voltage spike protection at the RF input to the amplifier. There will be a slight degradation of the amplifier performance. Please note that the optional input protection diodes cannot be used if DC voltages are applied to the RF line using input bias tees.

To order an amplifier with internal bias resistors, add the resistance to the part #. For instance, CITCRYO4-16-PD.

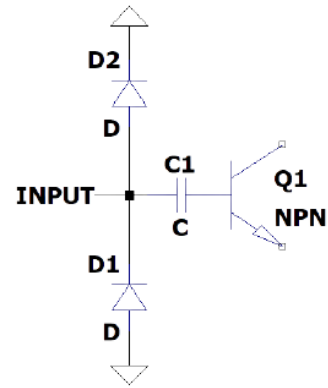

D1 & D2 = Input Protection Diodes

Figure 2. Protection Diodes Schematic

Product Care and Maintenance

- Use care to not bend (and break) the DC bias pin when tightening the output SMA connector.
- The amplifier should not be connected to the power supply when connecting the input connector.
- Set the power of Port 1 in your VNA to be less than -45 dB when testing the amplifier. Otherwise, the amplifier may saturate, and the data obtained will be incorrect.
- Do not attempt to open the amplifier.
- Electrostatic discharge may damage the amplifier.

Contact Information

Sales & Quotes

Sales@CosmicMicroTech.com

Non-Technical Questions

Name

Ms. Denise L. Smith

Email Address

Denise@CosmicMicroTech.com

Phone Number

+1 (424) 456-7722

Address

15711 Condon Avenue, Unit A3, Lawndale, CA 90260, USA

Technical Questions

Name

Mr. Stephen Smith

Email Address

Steve@CosmicMicroTech.com

Phone Number

+1 (424) 456-7744

Address

15711 Condon Avenue, Unit A3, Lawndale, CA 90260, USA

Specifications are subject to change without notice. Information supplied by CMT is accurate and reliable to the best of our knowledge.