



# CMTLF1S

## Single Stage Cryogenic SiGe Low Noise Amplifier

### KEY FEATURES

- Ideal for extremely low noise cryogenic applications.
- Powered from a single positive DC supply.
- Female SMA RF connectors.
- 2-pin Winchester DC connectors.
- Optional DC bias tees.
- Size 2.2 cm x 1.02 cm x 0.86 cm.

### PERFORMANCE FEATURES

- RF Frequency
  - 0.001 to 2.0 GHz
- Gain
  - < 22 dB
- Noise Temperature
  - < 5.5K
- Noise Figure
  - < 0.08 dB
- Optimum DC Power
  - $V_d = 3.0\text{ V}$
  - $I_d = 5.0\text{ mA}$



### Description

- The CMTLF1S, a single stage SiGe low noise amplifier, is intended for extremely low noise cryogenic applications. The amplifier uses resistive feedback to achieve good input match (S11) and high gain stability. The amplifier is optimum for the frequency range of 0.001 GHz to 2.0 GHz.
- It is powered from a single positive DC power supply which is optimum at 3.0 V.
- The amplifier is 22.2 mm x 10.16 mm x 8.59 mm excluding connectors. Input and output female SMA connectors.

# Electrical Specifications @ 12 K

Description	Typical	Minimum	Maximum
RF Frequency	2 GHz	0.001 GHz	3 GHz
Gain	22 dB	16 dB	24 dB
Noise Temperature	< 5.5K	4 K	8 K
IRL (-20log S <sub>11</sub>  )	< -15 dB	-15 dB	-20 dB
ORL (-20log S <sub>22</sub>  )	< -7 dB		
DC Voltage	3.0 V		
DC Current	5.0 mA		

# Typical Test Results – Optimum DC Bias @ 12 K

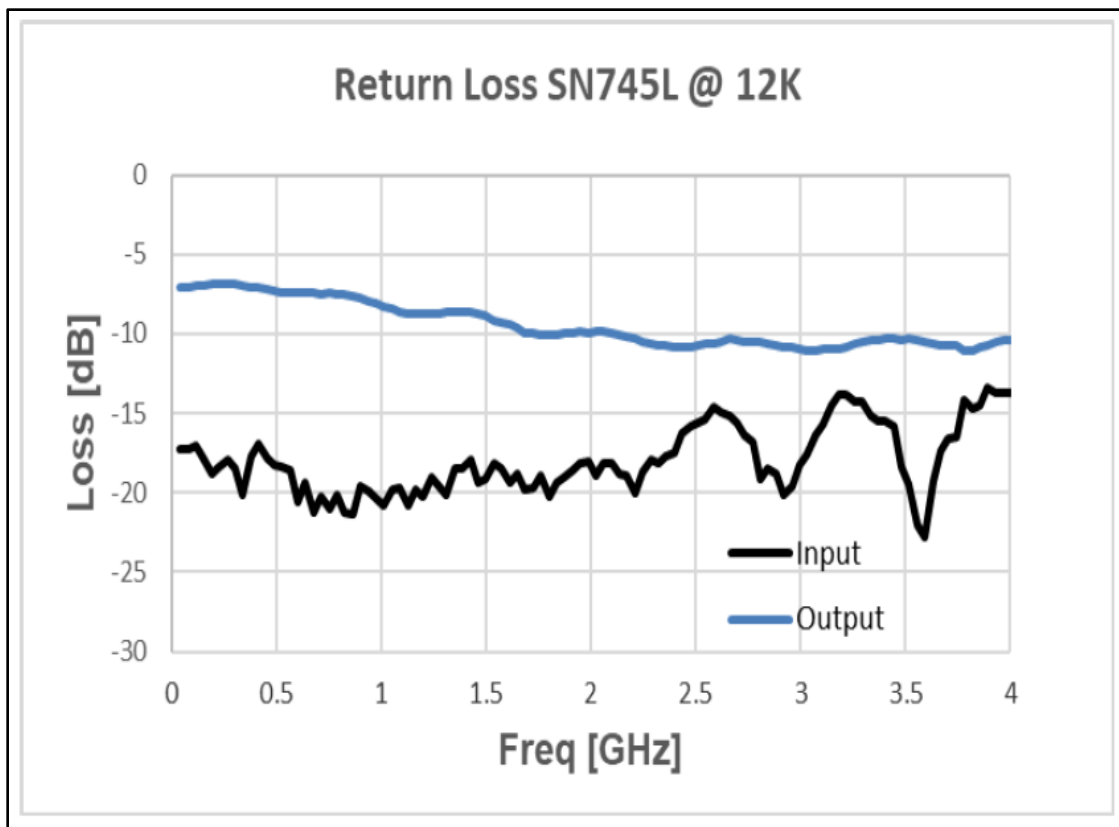
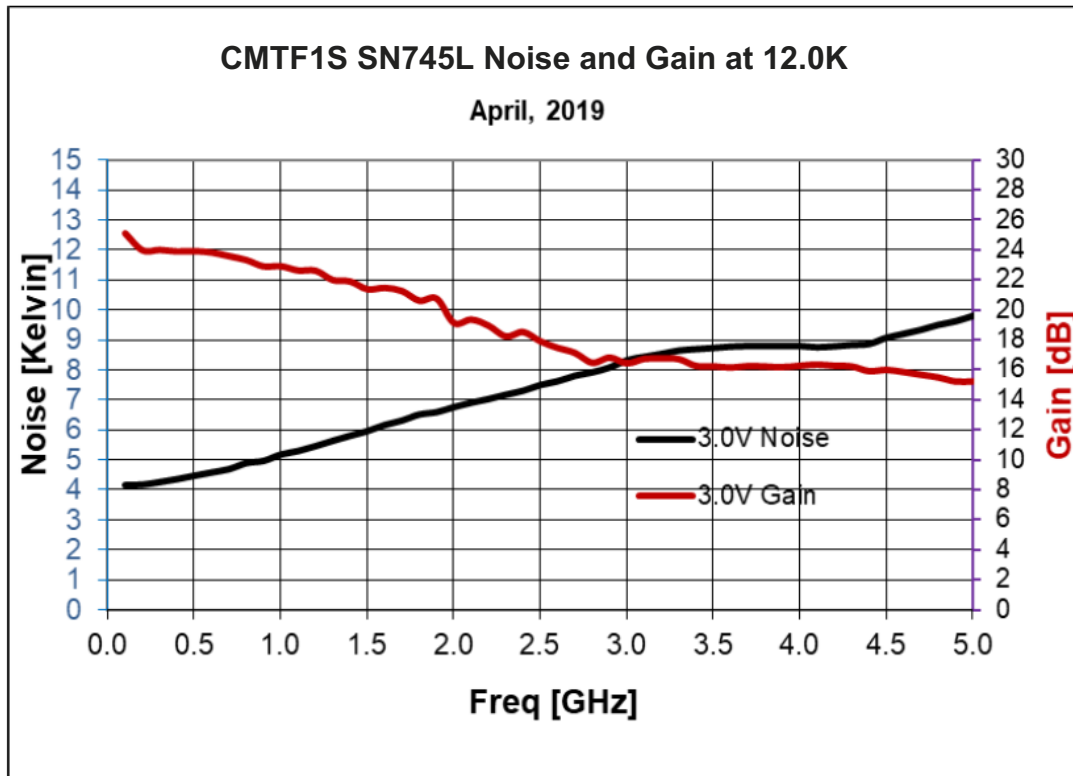

# Typical Test Results – 1 dB-Compression Point

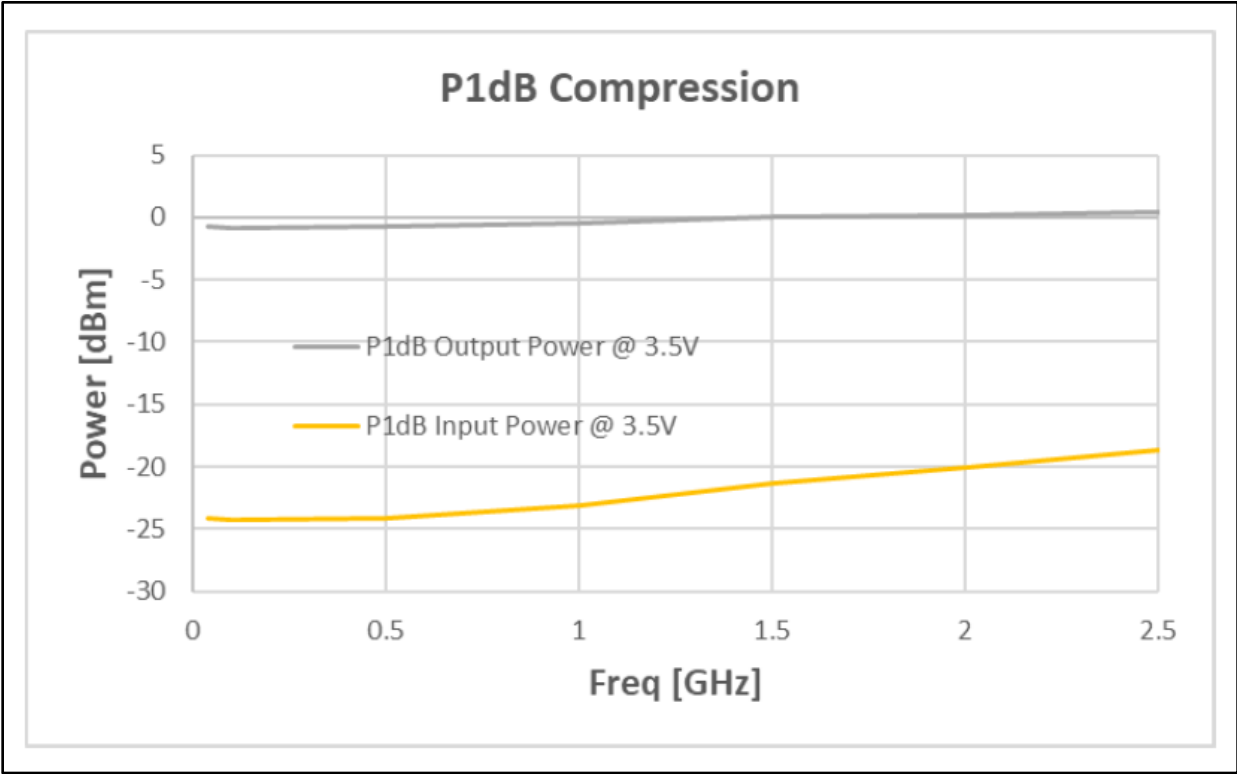

# CAD Housing Drawing

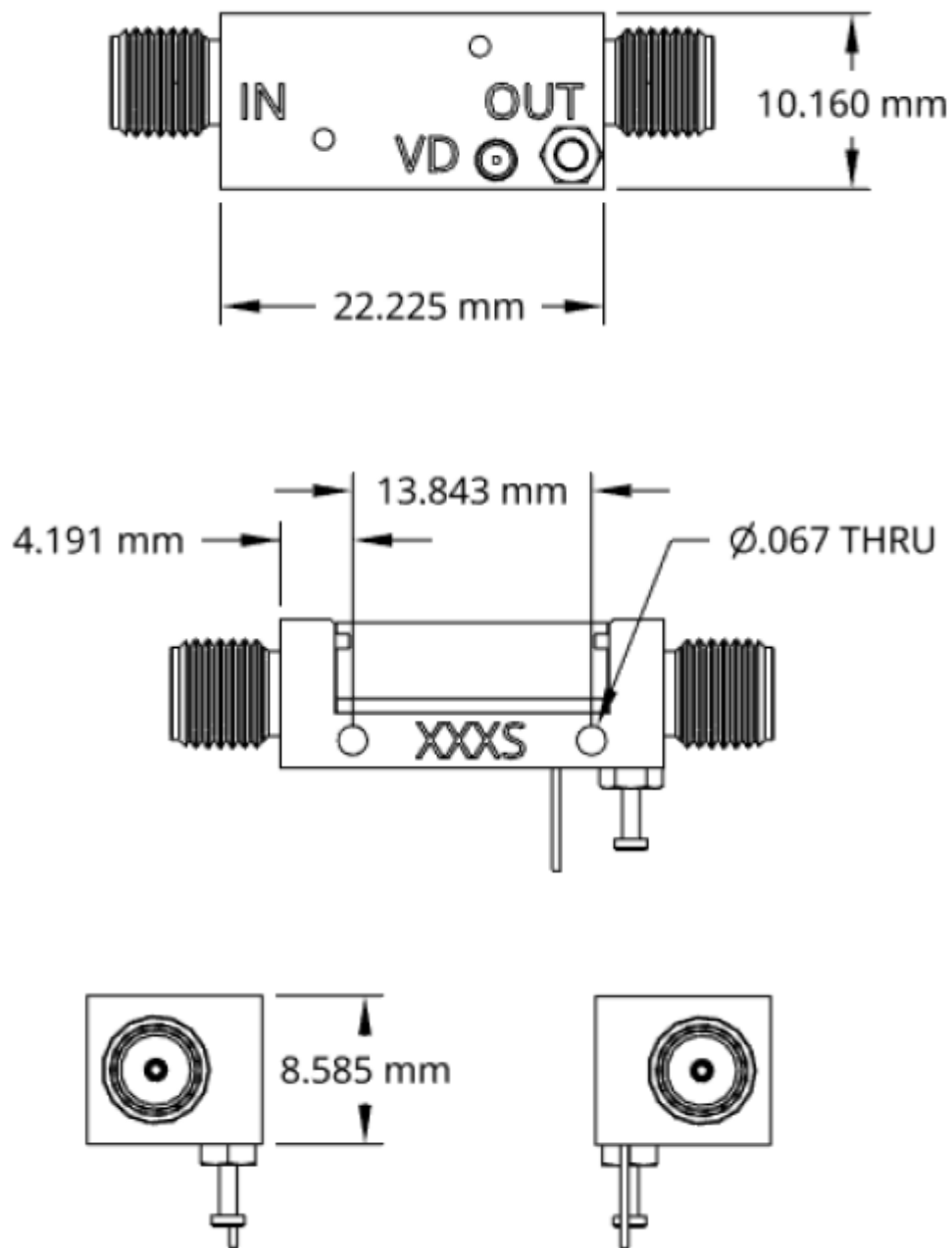

\*Dimensions are in mm

# Optional Input Protection Diodes

As an option, the amplifier can be supplied with ESD protection & voltage spike protection at the RF input to the amplifier. There will be a slight degradation of the amplifier performance. Please note that the optional input protection diodes cannot be used if DC voltages are applied to the RF line using input bias tees.

To order an amplifier with internal bias resistors, add the resistance to the part #. For instance, CMTLF1S-PD.

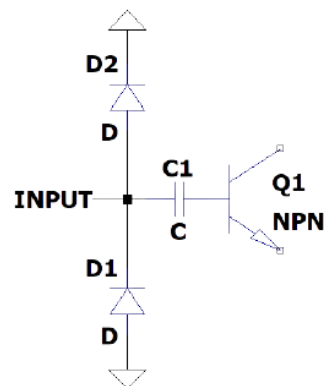

**D1 & D2 = Input Protection Diodes**

Figure 1. Protection Diodes Schematic

## Product Care and Maintenance

- Use care to not bend (and break) the DC bias pin when tightening the output SMA connector.
- The amplifier should not be connected to the power supply when connecting the input connector.
- Set the power of Port 1 in your VNA to be less than -45 dB when testing the amplifier. Otherwise, the amplifier may saturate and the data obtained will be incorrect.
- Do not attempt to open the amplifier.
- Electrostatic discharge can damage the amplifier.

# Contact Information

## Sales & Quotes

[Sales@CosmicMicroTech.com](mailto:Sales@CosmicMicroTech.com)

## Non-Technical Questions

**Name** Ms. Denise L. Smith  
**Email Address** [Denise@CosmicMicroTech.com](mailto:Denise@CosmicMicroTech.com)  
**Phone Number** +1 (424) 456-7722  
**Address** 15711 Condon Avenue, Unit A3, Lawndale, CA 90260, USA

## Technical Questions

**Name** Mr. Stephen Smith  
**Email Address** [Steve@CosmicMicroTech.com](mailto:Steve@CosmicMicroTech.com)  
**Phone Number** +1 (424) 456-7744  
**Address** 15711 Condon Avenue, Unit A3, Lawndale, CA 90260, USA

*Specifications are subject to change without notice. Information supplied by CMT is accurate and reliable to the best of our knowledge.*